

Veritas® Camber Roller Assembly

(05M09.05)

Introduction

The Veritas® Mk.II Honing Guide was introduced with a wide roller, providing a stable base so that blade edges remain perfectly straight and square to the blade. This is desirable for most blades; however, with larger smoothing planes, a perfectly straight blade can result in "plane tracks," small steps in the surface of the wood between plane strokes.

To avoid this, it is beneficial to add a slight camber or curve to the edge of the blade, rather than keep the edge straight. The result is that the blade takes a slightly scalloped cut and the resulting surface will be slightly wavy, a feature that is recognized as a hallmark of quality hand woodworking.

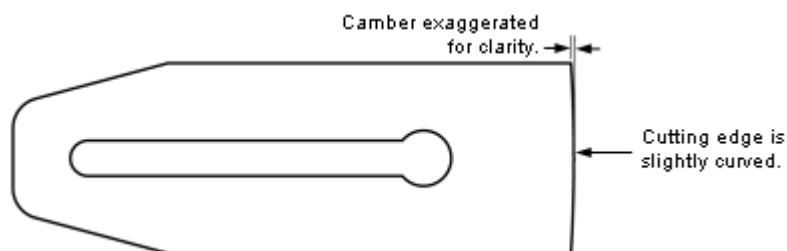

Figure 1: Typical plane blade with camber.

To facilitate the process of adding a slight camber to the edge of a blade, we have developed a barrel-shaped roller that allows the guide to rock slightly as pressure is applied across the blade. It is important to note that the amount of camber is controlled by the amount of pressure applied across the blade and the number of strokes taken at any one position. The resulting camber is **not** controlled by the shape of the roller.

Assembly

Remove the standard roller assembly from the Mk.II honing guide and attach the camber roller assembly, as shown in **Figure 2**. The major diameter of the camber roller is the same as the standard roller, so all bevel angle projections remain the same.

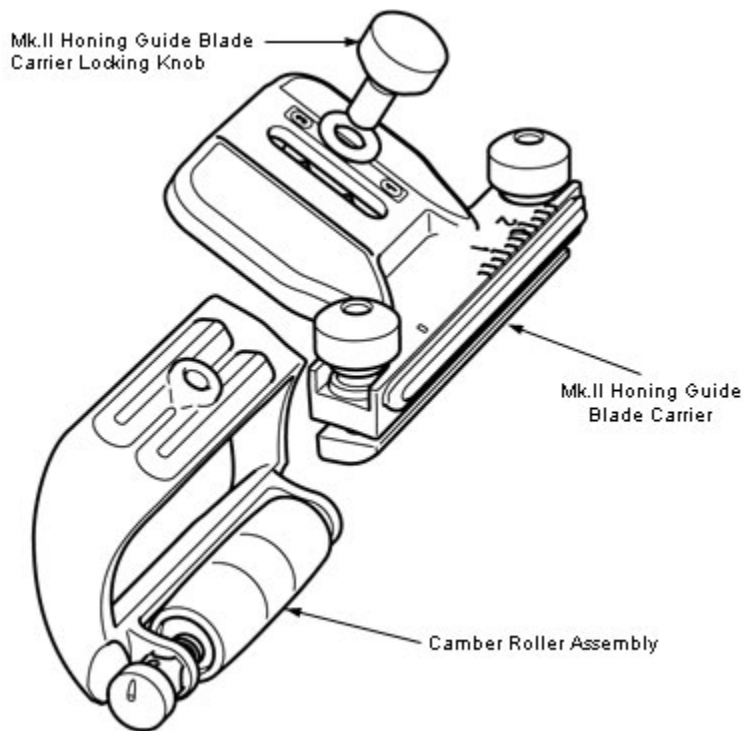

Figure 2: Installing the camber roller assembly.

Adding a Camber to the Edge of a Blade

There are many different theories regarding the necessary amount of camber and how to go about achieving it. In general, the basic procedure is to apply consistent finger pressure to various locations across the blade and to count the number of strokes at each location to ensure that equal amounts of metal are being removed.

Some references recommend using three locations (left, right and middle of the blade), others recommend five or more locations. The camber roller has a flat section in the middle to indicate a position straight across the blade.

Since these techniques will result in a blade that is slightly faceted across its bevel, some techniques call for taking a few strokes while varying the pressure across the blade during the stroke, in an effort to smooth out the curve.

Once you have obtained a smooth camber on the primary bevel, you can add a micro-bevel. Switch the honing guide eccentric to the desired location and repeat the process, again varying pressure across the blade and taking consistent numbers of strokes at each location.

In all cases, adding a camber to the edge of a blade requires a careful and consistent technique to get a consistent and even curve across the blade. With practice, you will develop just the right procedure.

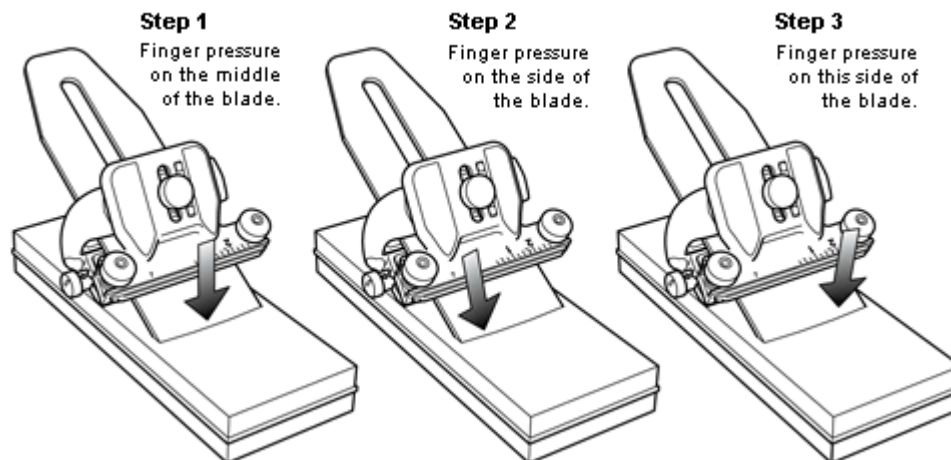

Figure 3: Basic process for honing a camber onto a blade.