

Veritas® Hold-Down

(#05G14.01)

Patented.

Requirements

The only requirements to use the Veritas® Hold-Down are round holes 3/4" in diameter and clearance under those holes for the post of the hold-down.

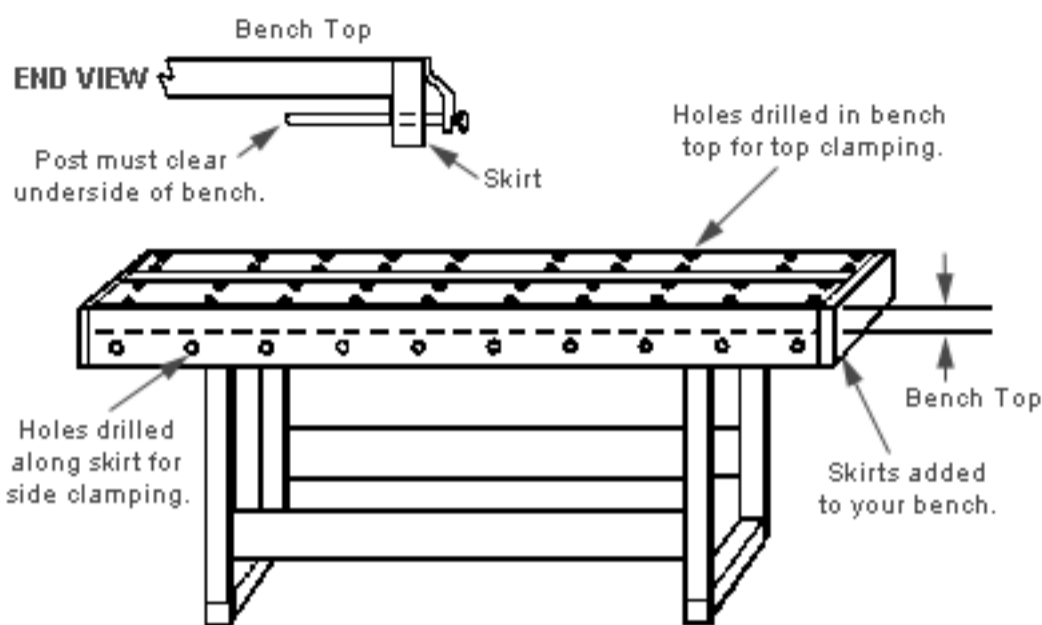

Fig. 1: Bench requirements.

Multiple Clamping Uses & Advantages

It is hard to list all the advantages and the endless variety of clamping uses for the Veritas Hold-Down. One distinct advantage over other hold-downs is that anywhere you can drill a hole, you can use the Veritas Hold-Down. The arm is always in the ready position for clamping. The hold-down is designed so that it can be gripped in one hand to insert it into a dog hole in a bench while the work to be clamped is oriented with the other hand. Slight downward pressure will lock the hold-down firmly in position. Simply turn the brass knob to apply the desired amount of clamping force. Clamping pressure is infinitely variable, depending on how much you turn the brass knob. In most cases, one or two turns is all that is required.

As well as being used in any location on the top of your bench, this hold-down excels when clamping boards or doors against the side of your bench. Simply add a skirt to your bench with 3/4" holes drilled along its length.

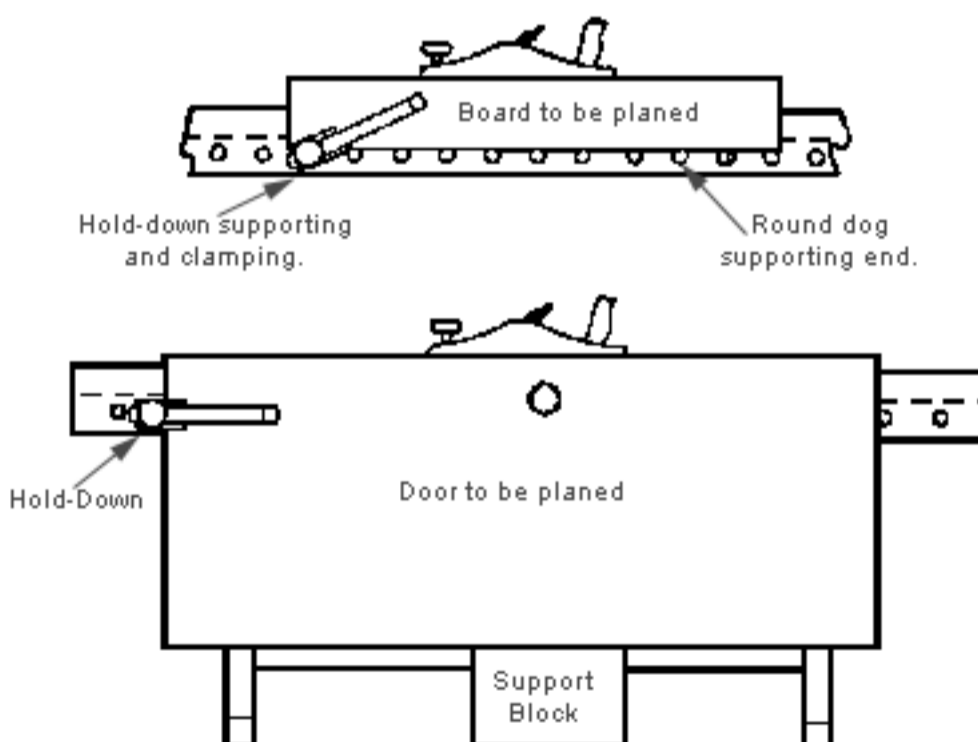

Fig. 2: Typical uses for side clamping.

The clamping configurations are endless. A Veritas Hold-Down paired with either a Veritas Round Bench Dog (#05G04.01) or Veritas Bench Pups® clamp (#05G04.03) makes planing boards an easy task. Clamping awkward shapes, such as carvings, becomes simple. In fact, it can hold down just about anything.