

## Veritas® Bar Gauge Heads

(#05N31.01)

Veritas® Bar Gauge Heads allow you to make adjustable gauges of any length, using standard 3/4" stock. These gauges have two advantages over tape measures. First, there is no error due to tape sag. Second, they prevent numerical errors such as remembering 27-3/16" instead of 27-5/16".

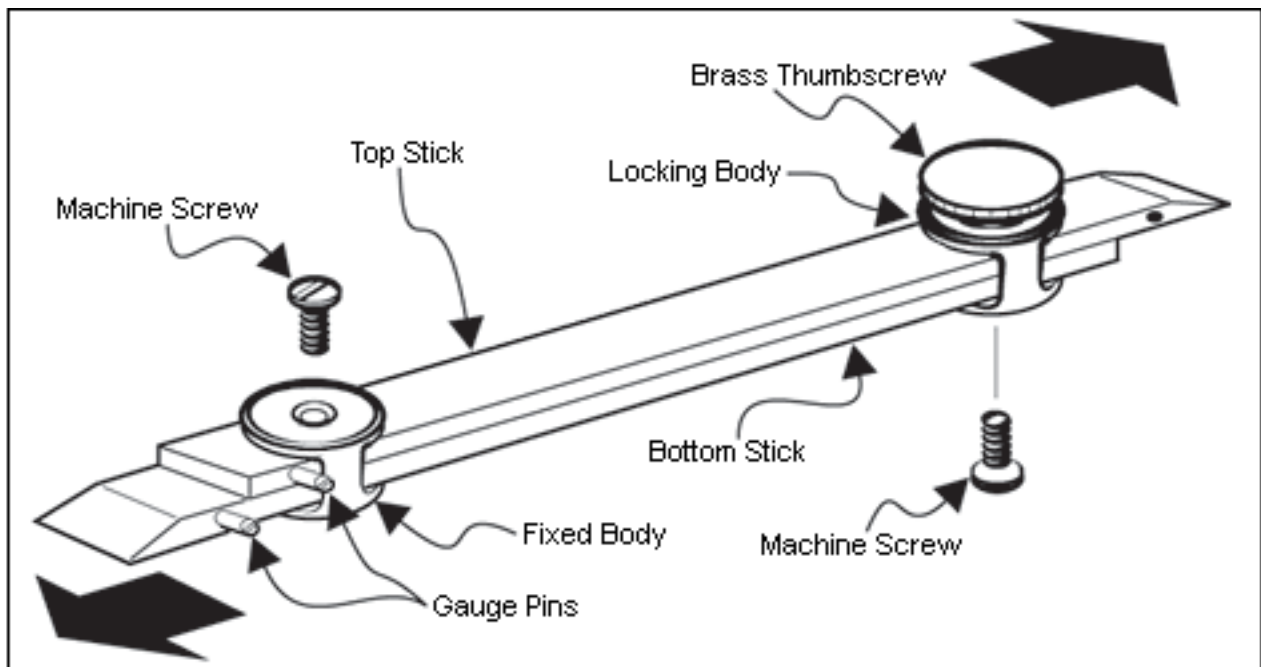

### Bar Construction

Using 3/4" stock, rip two 1/4" strips of equal length. Sand lightly to remove saw marks, and round over all edges. For greatest versatility, bevel the ends as shown. Drill a 1/8" through hole in the center at 1" from one end of each stick for the machine screws. Join the sticks to the gauge heads (as shown above) using the machine screws provided. Drill 1/8" holes, 1/2" deep (for the gauge pins) in the edge of each stick, side by side, 1/2" from one end when assembled at minimum closed length. Install pins with a screwdriver. Drill another pin hole at the other bevel end on the same edge.

### USING MEASURING STICKS

#### Checking For Squareness

Geometry dictates that the corners of a square or rectangle are 90° only when the diagonals are equal in length. Using a bar gauge of appropriate length, you can check this.

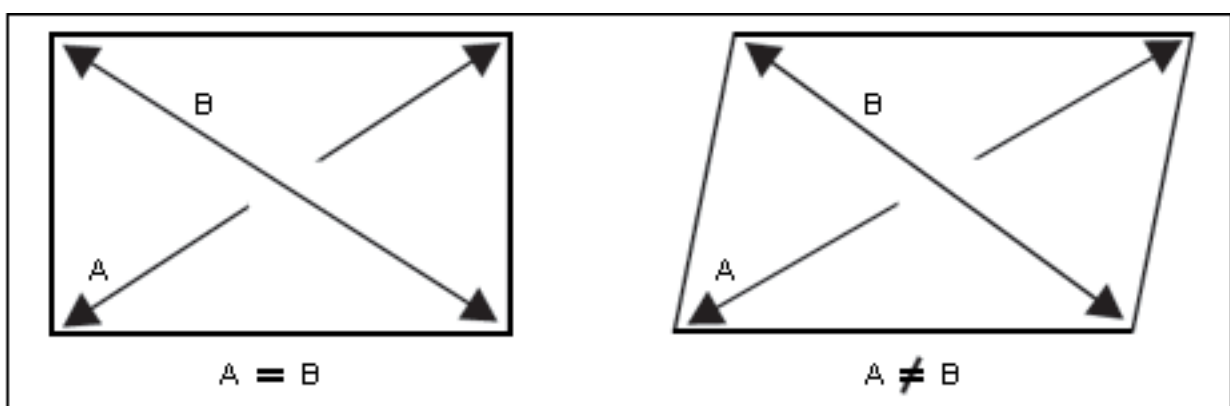

#### Measuring and Transferring Dimensions

You can use the gauge in hard-to-measure places, such as the inside of window frames. Extend the gauge until the bevel tips are touching opposing surfaces to get the correct inside dimensions. To transfer outside dimensions, use the gauge pins at the bevel ends. To transfer inside or outside dimensions smaller than the length of the sticks, set the pins so they are side by side when the bar gauge is closed. For multiple dimensions, mark each measurement with a pencil line next to either head. Notes added next to the marks help keep track of different dimensions.

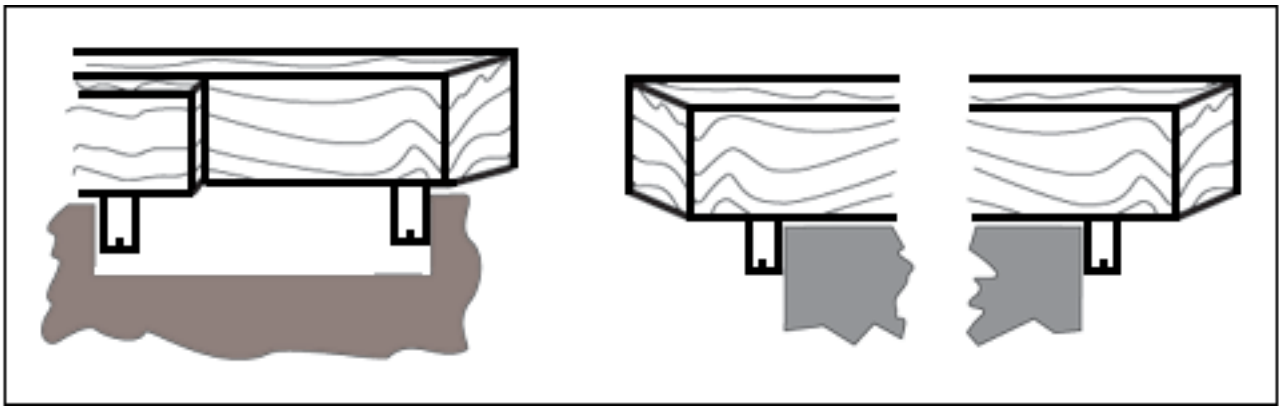

---

©Copyright 1998 to 2004 by Lee Valley Tools Ltd. and Veritas® Tools Inc. All rights reserved.