

Lie-Nielsen Toolworks Product - Use and Care Instructions

Iron Miter Plane

We are pleased to make this unique tool available once more. Weight (about 4 1/2 lbs.) and solidity make this plane ideal for many planing jobs on straight and end grain.

Its boxy construction is designed specifically for the tool to be used on its side, with or without a shooting board to shoot length, right angles, and, of course, miters. A second knob is provided, and mounts on either the front left or right side to facilitate your grip. David Charlesworth has a good discussion on shooting with this tool in *Furniture Making Techniques Vol. II*.

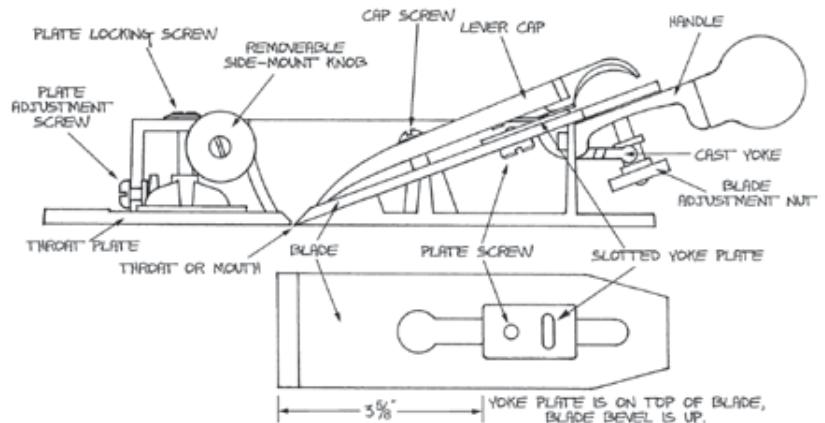

Geometry: The blade is set in the tool bevel up at 20° with a 25° bevel, making this a very large block plane, with an included cutting angle of 45°.

Blade Sharpening: The blade comes ready to use. Slight additional honing will increase performance. We often recommend a secondary bevel of 1° or 2°. This is most easily accomplished with a good honing jig. The secondary bevel will improve performance especially in hard woods. Further modifications of the bevel angles can be made to suit your style and the work.

Setting the Yoke Plate: The blade-adjusting nut engages a cast yoke that fits into a slotted plate screwed to the blade. The plate is installed with the slot to the rear of the blade. The front edge of the plate needs to be about 3 3/8" from the cutting edge of the blade to give you good range of motion. You can make a small jig with scraps of wood to set this distance. When replacing the plate, tighten the retaining screw very firmly to prevent slipping.

Mouth Adjustment: To adjust the mouth, loosen the locking screw on the front top and move the throat plate with the screw on the front of the tool. Adjustments may be made with a screwdriver or any handy coin. Re-tighten the locking screw, but do not over tighten. A fine mouth opening is appropriate for thin shavings, especially in difficult grained woods and finishing cuts.

Blade Adjustment: The blade adjusts easily and may be adjusted while your hand is on the rear knob. Turning the adjuster nut clockwise will advance the blade. The blade will adjust smoothly with the lever cap tensioned. Make sure the mouth is adequately open before advancing the blade to avoid damaging your edge.

Materials: The body is cast from Ductile Iron, a virtually unbreakable alloy. The castings are fully stress-relieved, a process that removes inherent stresses and ensures that the tool will remain flat and true. The cap is Manganese Bronze. Other parts are Brass, Steel and Cherry.

Lie-Nielsen Toolworks Product - Use and Care Instructions

The blade is A-2 Tool Steel hardened to Rockwell 60-62, cryogenically treated and double tempered. Our heat treating technique ensures that the blade will take and hold a very fine edge for a long time. After heat treating, the blade is fully surface ground on the top, back, and cutting edge, giving a smooth, flat surface that will take a mirror finish very quickly. The 3/16" thickness provides solid chatter-free cutting.

Maintenance: Sides and bottom are ground flat and square to .0015". Occasional light sanding on a flat surface with 400-grit wet/dry paper will keep your tool in new condition. Wood parts are finished with wiping varnish. Protect the body and blade from rust with a light oil, and occasionally oil the blade adjustment mechanism for smooth action.