



INDEX

PAGE NUMBER	DESCRIPTION	FIGURES
2	INDEX	-
3	INTRODUCTION	-
	BASIC SCRIBING PROCEDURE	-
	Single Plane Profile	1
	Scribing the Butt Profile	2
4	Cutting the Worktop	3
5	PROFILING AND FITTING ON TWO PLANES	-
	Process Overview	-
	Selecting Template Material	-
	STEP-BY-STEP GUIDE	-
	Worktop Alignment with a known datum	4
6	Rough Cut the Template	5
	Marking the Datum on the Template	5
	Scribing the Wall Profile onto the Template	6
7	Cutting the Template	-
	Positioning the Template on the Worktop	7
	Scribing from the Template to the Worktop	7
8	Cutting, Finishing the Profiled Worktop	8
9	PROFILING IN MULTIPLE PLANES	-
	Laying Tiles in Awkward Areas	9
	Making the Template	9
10	Scribing the Template	10
	Cutting the Template	-
	Copying the Working Area	11
11	Positioning the Template	12
	Re-Scribing the Profiles on the Tiles	13
12	Re-Scribing the Profiles on the Tiles (cntd)	13 - 14
13	ITEMS ENCLOSED	15
	DESCRIPTION OF PARTS	
	Assembled Shaft	15 A
	Retaining Cap	15 A1
	Shaft	15 A2
	Spring	15 A3
	Pencil	15 A4
	Circlips	15 A5
	Hub	15 A6
	O Ring	15 A7
	Tracing Wheels	15 B-C-D
14	M-POWER PRODUCT LIST	-

PERFECT•BUTT™

INTRODUCTION

The Perfect•Butt™ was designed to overcome a problem frequently encountered by tradesmen and enthusiasts alike when scribing in work surfaces, flooring or shelves to match uneven walls. Forget scraps of wood with a pencil jammed into a hastily drilled hole, this innovative tool now takes the guess work out of what used to be a hit and miss chore. Now your pencil simply remains in the centre of any of the 3 tracing wheels allowing an accurate profile to be easily drawn every time.

Please register this purchase for your free lifetime guarantee. Either return the enclosed form by post or register on-line at www.m-powertools.com

Tip: Before committing yourself to cutting an expensive worktop or some other material, practice profile marking and cutting on scrap material such as cardboard, plywood or MDF offcuts. This will ensure that you develop the correct technique and build confidence.

BASIC SCRIBING PROCEDURE

Single Plane Profile

This example is for fitting a kitchen worktop flush up to any wall with an irregular profile. The principles behind this process apply to any single plane profile such as fitting a shelf or when fixing two work pieces together.

Initial Alignment (Fig 1)

Rest the worktop on the cabinet carcasses and position it up against the wall ensuring that the front edge is parallel to the front of the kitchen cabinets (Fig 1a). Locate and measure the largest gap between the wall and the worktop rear edge (Fig 1b). Select the P.B. wheel whose radius is just greater than the width of the gap (i.e. when the edge of the wheel is pressed against the wall, the pencil point will still mark the worksurface).

Note: Smaller wheels give greater detail when profiling complex surfaces.

Fig 1 (Bird's-eye View)

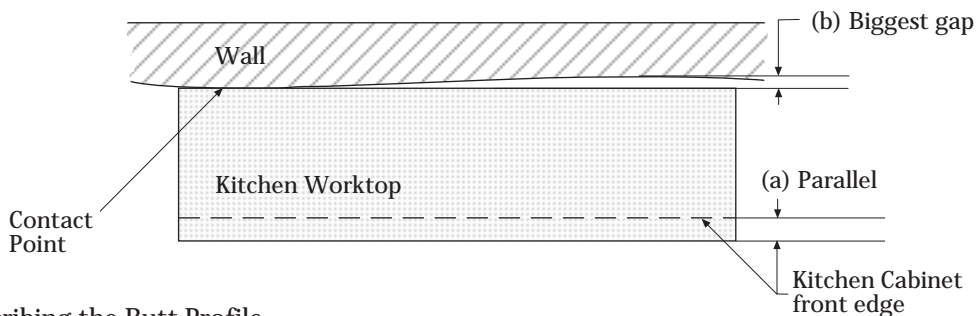

Scribing the Butt Profile

Ensure the worktop is secure and does not move.

Fit the chosen wheel to the pencil shaft assembly.

Starting at whichever end of the worktop you prefer, press the Perfect•Butt™ wheel flat onto the worktop with the edge of the wheel touching the wall. This will ensure an

PERFECT • BUTT™

accurate transfer of the wall profile to the worktop. Hold the knurled shaft near the base and run the wheel along the wall for the entire length of the worktop (Fig 2a). The internal spring in the handle will keep the pencil in gentle contact with the surface while the wheel is traversed.

Note: Your pencil line may not show on some laminated surfaces. We suggest you apply a strip of masking tape where the pencil will run. This will also help avoid chipping the surface when the worktop is cut to shape.

Examine the scribed line. If this indicates that too much material will be cut off, then reposition the workpiece away from the wall by an appropriate distance and re-scribe as required.

Fig 2 (Bird's-eye View)

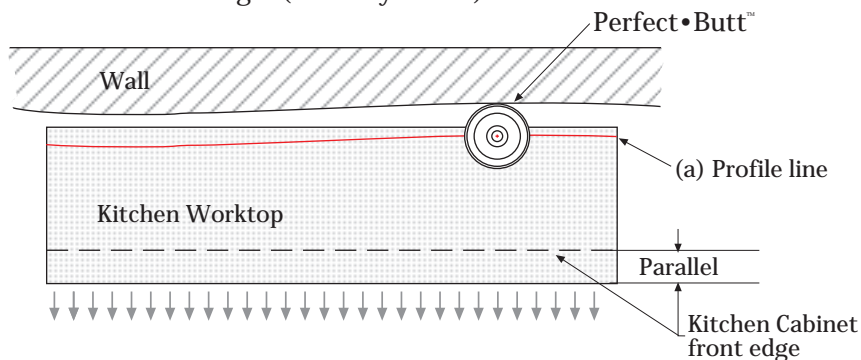

Cutting the Worktop

The wall profile has now been transferred to the worktop. When cutting the worktop, always cut to the waste material side of the scribed line. This will ensure you do not cut into the good side of the worktop and there will be minimum material to remove for final hand-fitting. If you have previously practised this technique on scrap and you have cut accurately to the scribed line, the final fit should be acceptable first time.

Fig 3 (Bird's-eye View)

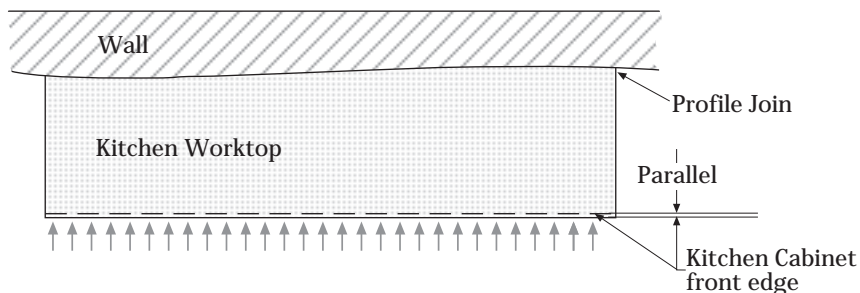

PERFECT • BUTT™

PROFILING AND FITTING ON TWO PLANES

Fitting a kitchen worktop into a corner with two irregular walls.

If both the walls are distorted or untrue then a template will be required to copy both wall profiles simultaneously onto the worktop.

Process Overview

- Place the worktop on the kitchen cabinets as near to its final desired position as possible with the front edge correctly aligned.
- Rough cut a template (cardboard etc.) to cover the area where you wish to fit the worktop.
- Align the template and scribe both wall profiles onto the template using the Perfect • Butt™
- Cut out the template along the scribed lines. When the Perfect • Butt™ is then run along the outer-edge of this template, the wall profiles will be reproduced onto the worktop with a scribing line (see detailed instructions for external corners on the template). The worktop may then be cut and the edge finished to carefully match the scribe line indicated by the Perfect • Butt™. The worktop will now fit both irregular wall profiles and can be fixed in position.

Selecting Template Material

Many materials can be used as a template as long as they are greater than 2mm in thickness with an edge that will not compress when it is used to trace against with the Perfect • Butt™ wheel. Suitable materials include thick card, packing cardboard, MDF, plywood, hardboard and polyfoam.

STEP-BY-STEP GUIDE

Worktop Alignment with a Known Datum

Rest the worktop on the kitchen cabinets and position it into the corner where it is to be fitted. Ensure that the worktop is parallel to the front edge of the kitchen cabinets (Fig 4a) - a known datum - and that both the back and side edges touch their respective walls (Fig 4b).

Fig 4 (Bird's-eye View)

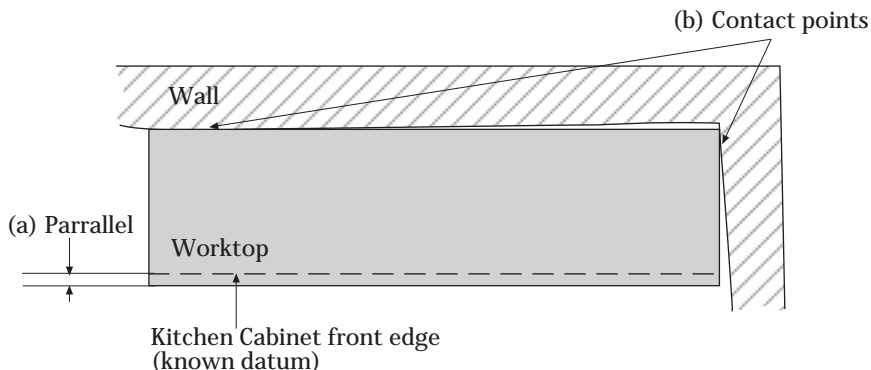

PERFECT • BUTT™

Rough Cut the Template

The template will need to be at least as wide and deep as the worktop you wish to fit. It may need to be wider and deeper than the worktop in places to roughly cover the gaps, depending on the degree of irregularity in both wall profiles. You may join multiple pieces of suitable material together to create larger templates where necessary, but when doing this ensure that the final template assembly is sufficiently rigid or has assembly marks so that the pieces can be accurately re-aligned if disturbed. The idea is to end up with a rough-cut template that follows the existing wall profile to within an inch (25mm) (Fig 5a). This gap can be spanned by the smallest wheel.

Marking the Datum on the Template

Once you have your rough-cut template you must ensure that it can record the profile accurately. Mark each side of the template where it intersects with the front edge of the worktop (Fig 5b). As you have already aligned the worktop parallel to the kitchen cabinets, these two edge marks now provide the template with a fixed reference line to the datum, a known straight edge. Mark a line between these edge marks and cut the template along this line to give the template its datum line.

Fig 5 (Bird's eye View)

(Side View)

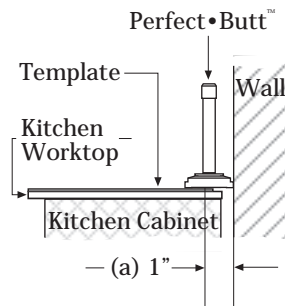
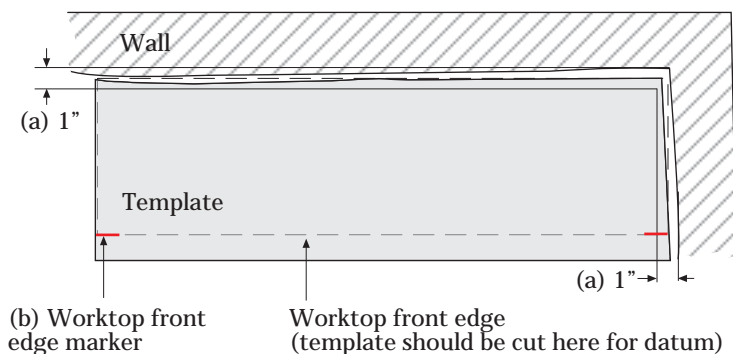

Scribing the Wall Profile onto the Template

With the template rough cut to within an inch (25mm) from the walls you wish to profile and correctly aligned with the datum (template and worktop aligned) (Fig 6a) you are ready to scribe a profile onto the template (Fig 6) (overleaf). You may wish to tape or clamp the template in place so that its alignment with the datum is fixed.

Important: Any movement of the template at this stage will lead to inaccuracy.

The Perfect•Butt™ should be held so that the wheel underside lies flat against the template surface with the wheel edge against the wall (Fig 5 Side View). Run the wheel along the entire length of both walls, including the corner angle, so that the wall profiles are transferred onto the template (Fig 6b).

Fig 6 (Bird's-eye View)

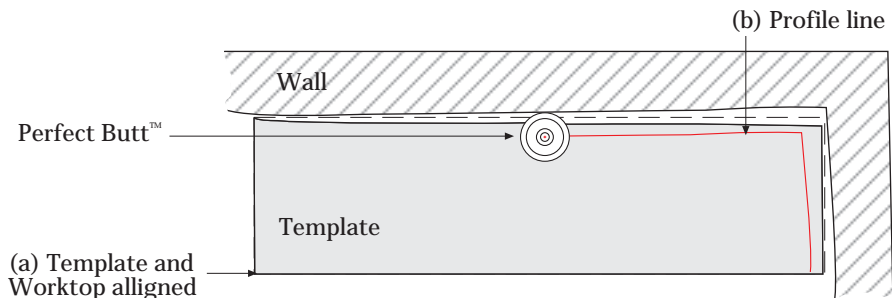

Cutting the Template

Remove the template from the worktop and carefully cut it along the scribed profile line. Always cut on the waste side (wall side) of the line, and finish up to the line by hand.

Note: Time spent now on template accuracy will be reflected in the fit of the finished worktop and the wall profile.

Positioning the Finished Template on the Worktop

Once the template has been cut, it must be positioned on the worktop leaving enough room for the Perfect•Butt™ to traverse round the outside without the pencil going outside the worktop surface. To retain the desired alignment with the cabinet carcasses, the template datum edge must remain parallel to the front edge of the worktop (Fig 7a). The closest points of the template to the edges of the workpiece should be slightly greater than the radius of the chosen scribing wheel.

Scribing from the Template to the Worktop

Once the template is correctly aligned and positioned, it should be fixed using tape or clamps. Place the Perfect•Butt™ so that the wheel edge butts against the template edge and the wheel is lying flat against the worktop, then scribe around the entire edge of the template. This will transfer a line that matches the original wall profiles onto the worktop (Fig 7)

Examine the scribed line. If this indicates that too much material will be cut off, then erase the first lines, reposition the template by an appropriate distance as required and scribe again around both template edges.

Important: External template corners will trace with an arc (Fig 7b) requiring you to finish the true corner by projecting lines A and B until they intersect at point C (Fig 7b).

Note 1: Ensure the pencil is sharp and that the tracing wheel is flat on the surface.

Note 2: If the wheel skids rather than rotates it will still provide an accurate line.

Fig 7 (Bird's-eye View)

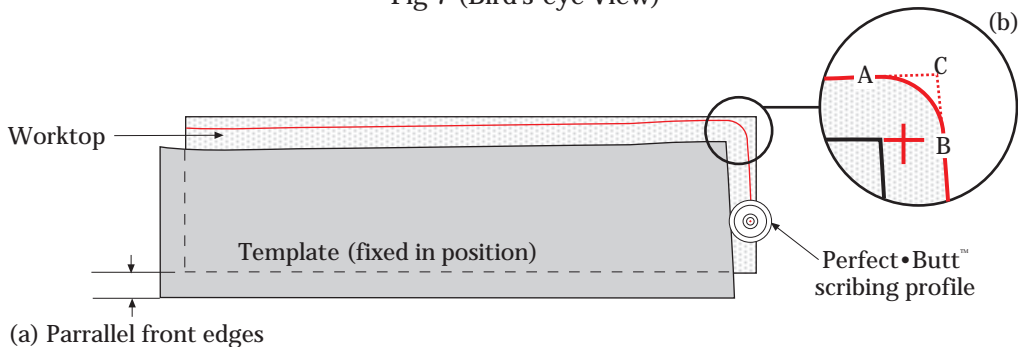

Cutting, Finishing and Fitting the Profiled Worktop

The worktop will now be marked with a scribed profile line and can be cut to size. Cut on the waste material side of the scribed line. Check the worktop against its final fixing position. You may need to finish the worktop edges using hand tools to ensure that the edge perfectly matches the profile line.

Once you are happy that the worktop edge matches the profile line it should now lie flush to both walls while remaining parallel to the cabinet carcass (Fig 8). You can now secure the worktop in place.

Fig 8 (Bird's-eye View)

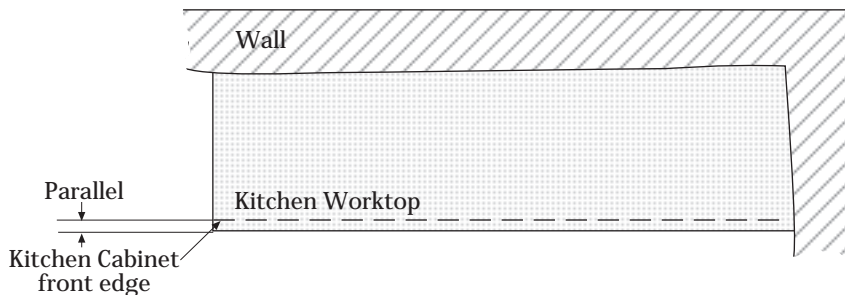

MORE COMPLEX SCRIBING AND TEMPLATE TECHNIQUES

See the website for details on how to template around complex areas such as sink plinths and toilet bases, and to match walls to sheet flooring material such as linoleum or floor tiles.

These data sheets can be downloaded from the Perfect • Butt™ pages of the m-power website at www.m-powertools.com

PERFECT • BUTT™

PROFILING ON MULTIPLE PLANES

Laying Tiles in Awkward Areas

In this example we will show how to fit floor tiles into a corner recess in which there is a pedestal obstruction such as for a wash-hand basin or W.C. While this procedure may, at first, appear somewhat complex, a quick practice using scrap materials will soon bring familiarity with the technique.

Lay a complete line of tiles up to the point where an obstacle or wall will interrupt the next line of tiles (Fig 9a). The edge of this tile line then becomes the datum (known point of reference) for the procedure described below. The area beyond this line, where tiles need to be trimmed to shape, will be known as the work area.

Making the Template

Select a suitable template material. Rough cut this template to within an inch of the work area boundary (Fig 9b). Ensure that the front edge of the template nearest the existing tile line is cut straight to match that edge, as this datum will be used as an alignment reference later (Fig 9c). You will also need to mark on the template the position of the outermost tiles to ensure accurate alignment after the template is cut to size (Fig 9d). Align these marks with the inside edge of the exterior tiles, as this will give you a precise reference line.

Note: The template may need to be made in several pieces to allow you to fit it into the desired area. Simply tape the various pieces together when you are happy with the template shape (Fig 9e).

Note: The usually unsuitable double corrugated cardboard may be used as template material when using spaced tiles as small discrepancies can be taken up with normal tile spacing and grout.

Fig 9 (Birdsye View)

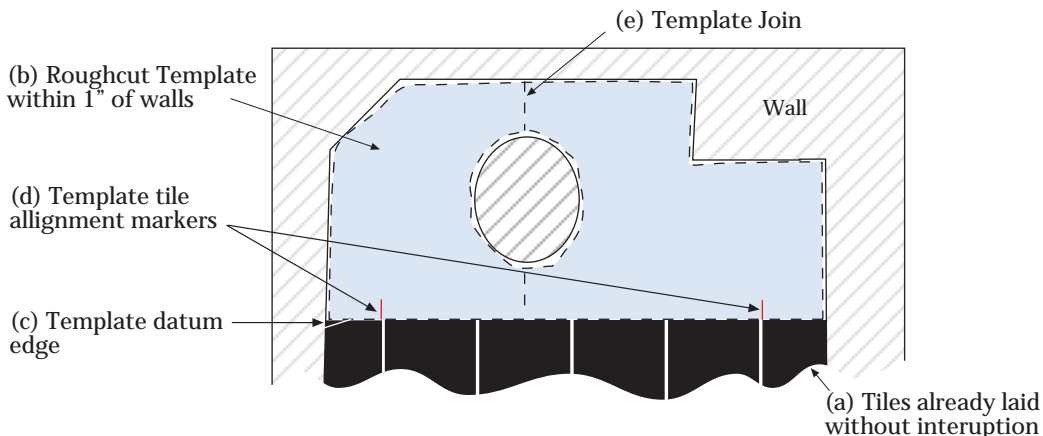

PERFECT • BUTT™

Scribing the Template

Secure the template so that it does not move. The easiest method is to tape the front edge to the existing tile line. Take the Perfect•Butt™ and scribe the profile of all edges within the work area on to the template, ensuring the wheel is lying flat on the surface and is fully butted against the objects being recorded (walls, pedestal) (Fig 10a).

Fig 10 (Birdseye View)

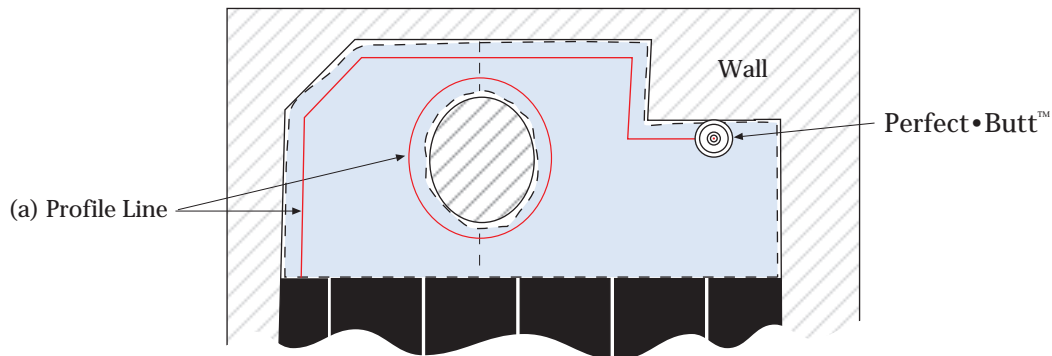

Cutting the Template

Once you have scribed the template, remove it from the work area and carefully cut it along the scribed lines. (Do not cut away the datum side)

Note: When using a dense template material such as thin MDF, always cut on the waste material side of the profile line and finish by hand where necessary. With cardboard, cut as accurately to the line as possible.

Copying the Working Area

In a clear area, layout the appropriate number of tiles required to cover the work area (Fig 11). This can be done by measuring the greatest length and width (Fig 11a) of the actual work area and then creating a matrix or grid of tiles that completely covers this area (Fig 11b). The tile matrix should be butted on its front edge against a batten or appropriate straight edge that represents the datum of the existing laid tiles (Fig 11c).

Note: You may wish to temporarily glue or tape the exterior tiles in your matrix in place, especially smaller and lighter types which may move when you scribe across them from the template later on. When working with ceramic or stone tiles, remember that spacers representing grout width must also be added between tiles when laying them out, and that this also includes spacers between the batten (representing the existing laid tile line datum) and the first row of tiles in the work area.

Fig 11 (Birdseye View)

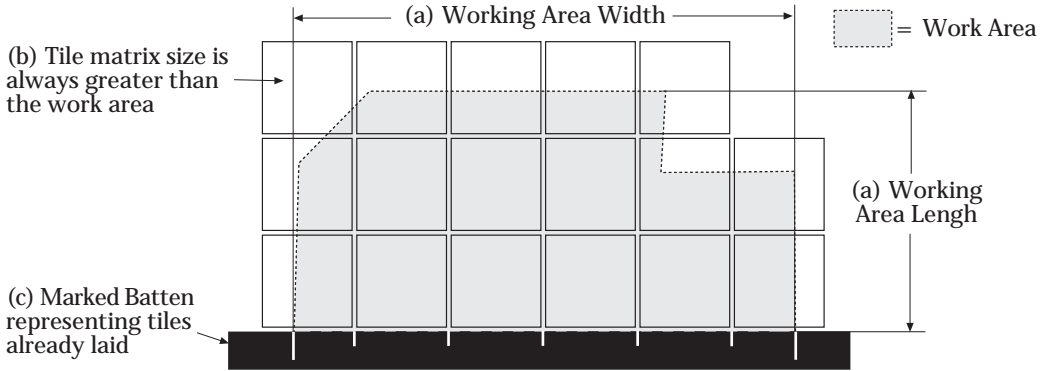

Positioning the Template

Align the template so that the front edge rests butted against the tile datum edge (Fig 12a) and the template tile width indicators are aligned at the interior edge of both exterior tiles (Fig 12b). Once correctly aligned, secure the template in place by taping its datum edge.

Fig 12 (Birdseye View)

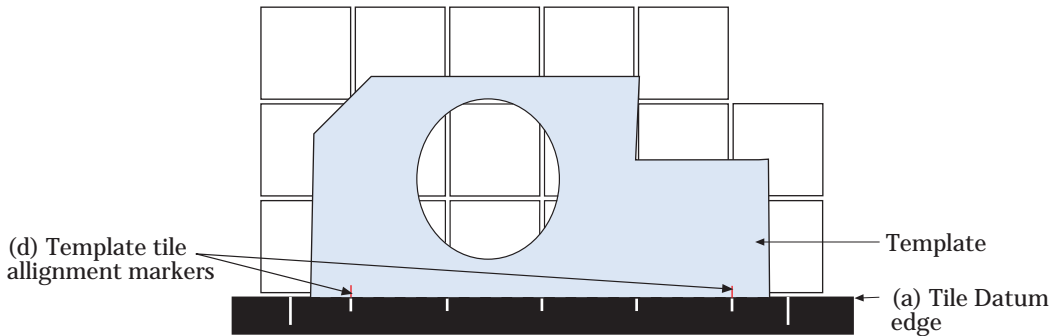

Re-Scribing the Profile on the Tiles

Use the Perfect • Butt™ with the same sized wheel used to create the template and scribe all appropriate edges of the template so that the profile line of the work area is transferred to the tile matrix you have laid out (Fig 13). You may wish to number the tiles before

PERFECT•BUTT™

cutting them as an aid to repositioning them once cut back in the work area.

Important: External template corners will re-scribe with a rounded edge as shown in (Fig13a). You will need to complete these corners with a straight edge or by eye where necessary.

Note: You may find it easier to mark glazed tiles using a Chinagraph (wax) pencil in the Perfect•Butt™. Alternatively, apply masking tape to the tiles in the areas which will be traversed by the Perfect-Butt pencil.

Fig 13 (Birdseye View)

Fig 13a

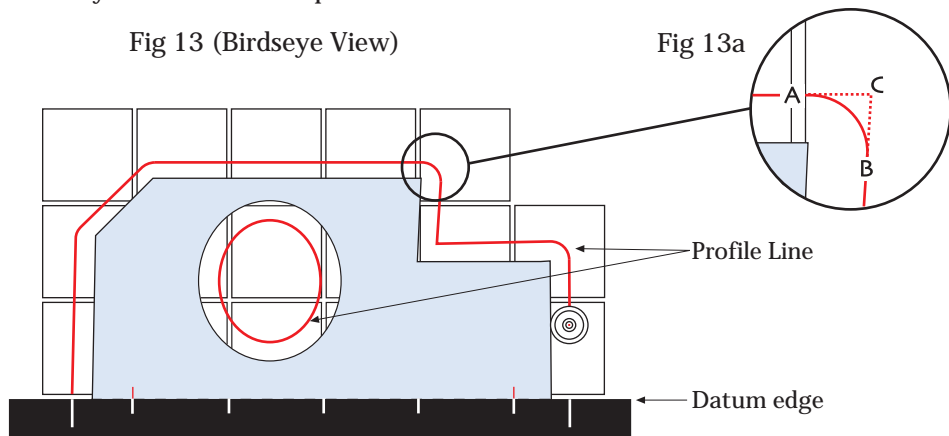

Cut Out Your Tiles for the Work Area. With composition tiles which are laid without gaps, cut and finish the tiles to the waste side of the profile line, then trim as required for final accuracy. For ceramic tiles which will be spaced and grouted, allow sufficient space for the grout at the wall and pedestal boundaries by cutting slightly inside the marked profile. To avoid unsightly errors, this grouting allowance should be established first on those tiles which will end up in a hidden, area. If errors are made and tiles are spoiled, place a fresh uncut tile on the matrix in the appropriate position and rescribe from the template as described above. You should now have a set of tiles ready to be laid into the work area (Fig 14).

Fig 14 (Birdseye View)

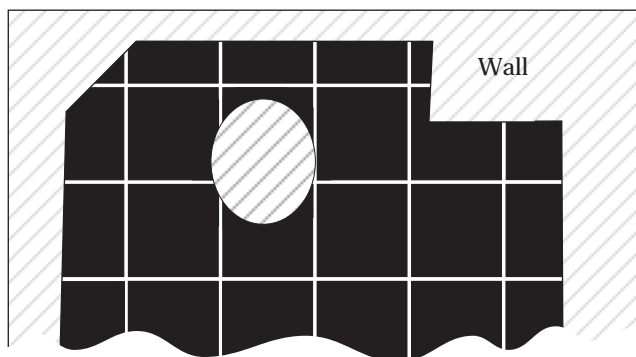

Do contact M•POWER™ if you identify any novel application for the Perfect•Butt™ or have any other polite suggestions for its use.

PERFECT•BUTT™

ITEMS ENCLOSED (Fig 15)

- A Assembled Shaft
- A1 Spring Retaining Cap
- A2 Shaft
- A3 Pencil Spring
- A4 Pencil
- A5 Circlips x 2
- A6 Hub
- A7 O Ring
- B D50mm Tracing Wheel
- C D70mm Tracing Wheel
- D D90mm Tracing Wheel

DESCRIPTION OF PARTS

Assembled Shaft: The holding point and axis around which the Hub and Tracing Wheel rotate.

Retaining Cap: Acts with the spring to provide gentle downward pressure on the pencil.

Shaft: Houses the spring and pencil. Knurled finish for a comfortable grip.

Spring: Applies pressure to the pencil to maintain a smooth even line.

Pencil: Housed in the shaft the pencil marks at the axis of the tracing wheel.

Note: If you need to reduce the pressure of the pencil, the retaining cap may be partially unscrewed.

Alternativley the pressure may be reduced by shortening the length of the pencil.

Circlips: Secure the hub to the shaft.

Hub: Tolerance fit compatible with all tracing wheels.

O Ring: Holds the tracing wheels onto the internal wheel while enabling them to be changed quickly and easily.

Tracing Wheels: Diameters of 50mm - 70mm - 90mm give the Perfect•Butt™ the ability to scribe profiles of varying differentials.

Fig 15 (Side View)

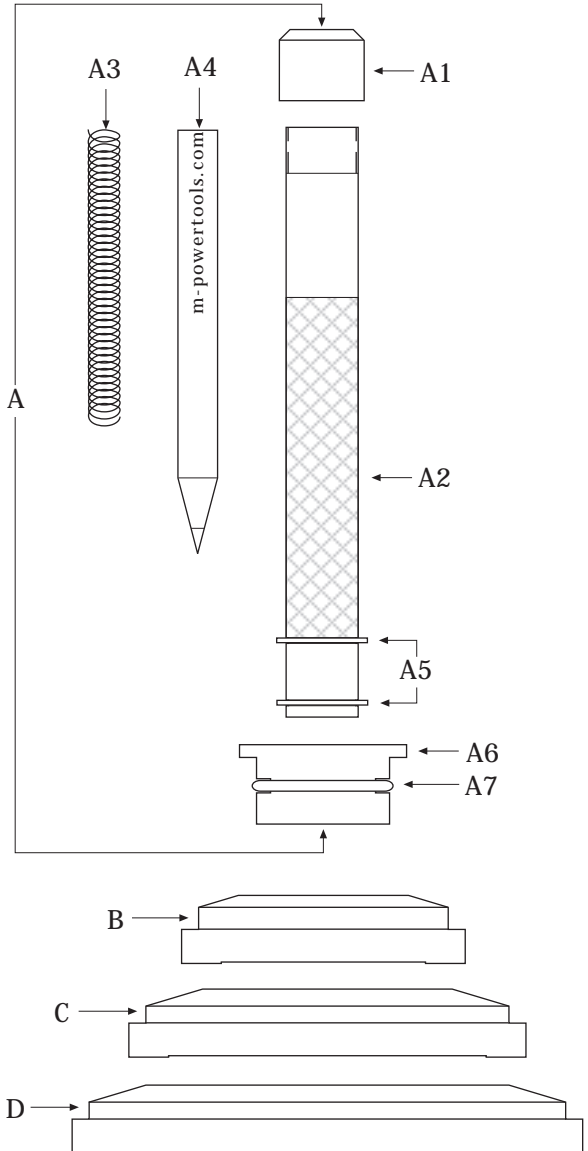



M-POWER™ PRODUCT LIST

Product	Description
M3•Square™	3D-Tri Square and combination marking tool
Tri•Scribe™	Flat lying Trammel Compass and marking scribes
Tri•Blade™	Cutting accessory to the Tri Scribe
Point•2•Point™	Speed gauge for equidistant measurements
R1™	Right handed tape measure
Perfect•Butt™	Profile scribing device
Mach•2™	Vacuum driven hold down workbed
Mini•Mach™	Portable vacuum hold down workbed
U•Mach•Kit™	Self build Mini Mach kit
Big•Mach•Kit™	Self build industrial sized vacuum hold down kit
Stable•Mate™	Compass and offset baseplate for 1/2" & 1/4" routers
Mod•Rods™	Modular threaded router guide rods 8mm, 10mm, 12mm